

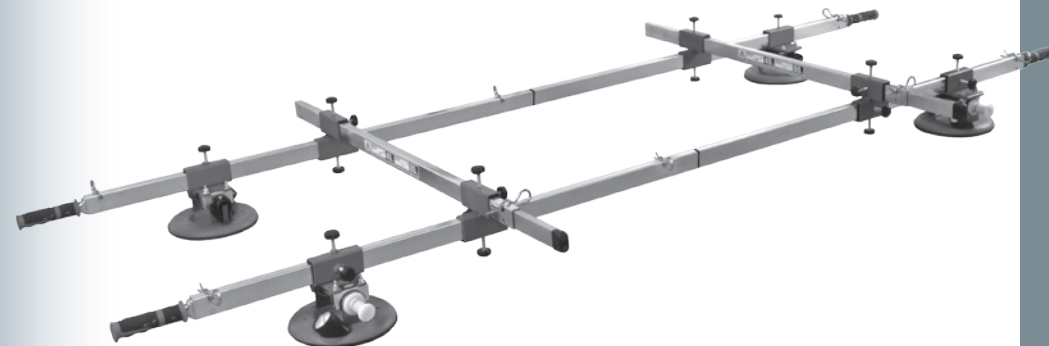



POSA - TOOLS - FA
TECHNORIUM



Art. 300-70-TR

-  SISTEMA MODULARE DI MOVIMENTAZIONE LASTRE - KIT COMPLETO
-  MODULAR SYSTEM OF HANDLING OF SLABS - FULL KIT
-  SYSTÈME MODULAIRE DE MANIPULATION DES GRANDS CARREAUX - KIT COMPLET
-  HANDHABUNG BAUKASTEN DER GROSSE FLIESEN - KOMPLETT-SET



32 Kg



100% MADE IN ITALY



VIETATA LA MOVIMENTAZIONE CON MEZZI DI SOLLEVAMENTO
NOT FOR MOVEMENT WITH LIFTING EQUIPMENT
PAS DE MOUVEMENT AVEC EQUIPEMENT DE LEVAGE
NICHT ZUR BEWEGUNG MIT LIFTING AUSRÜSTUNG

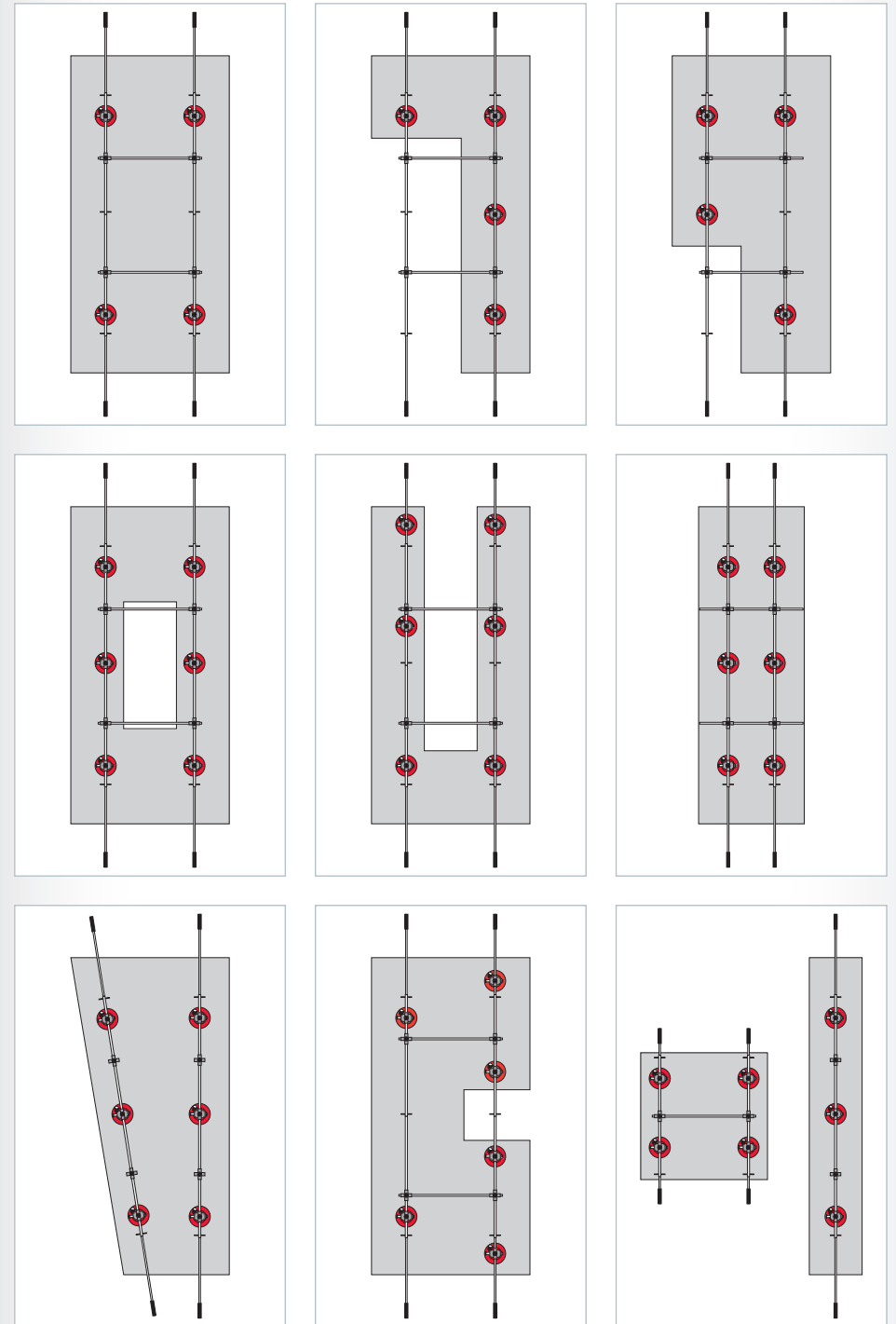
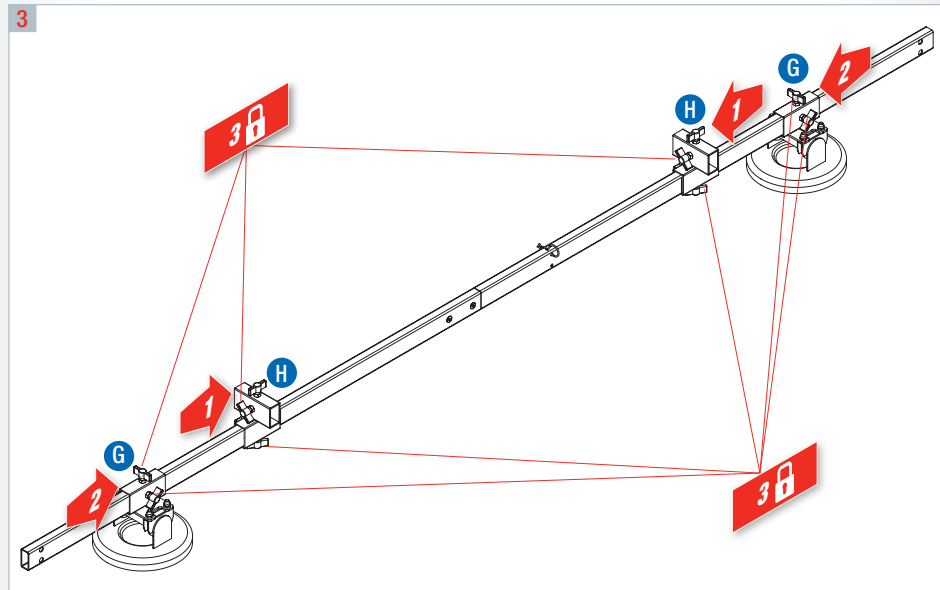
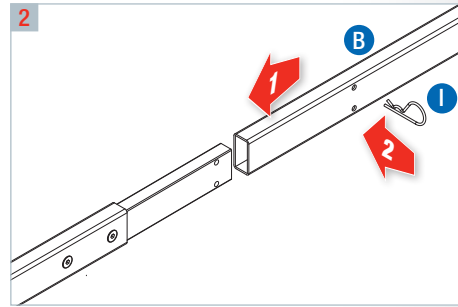
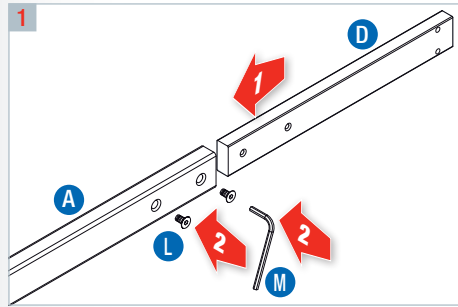
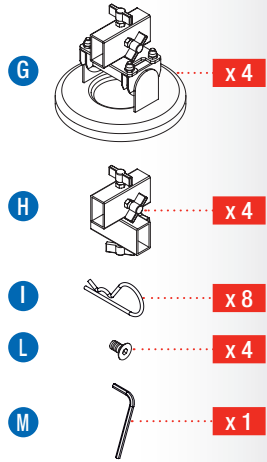
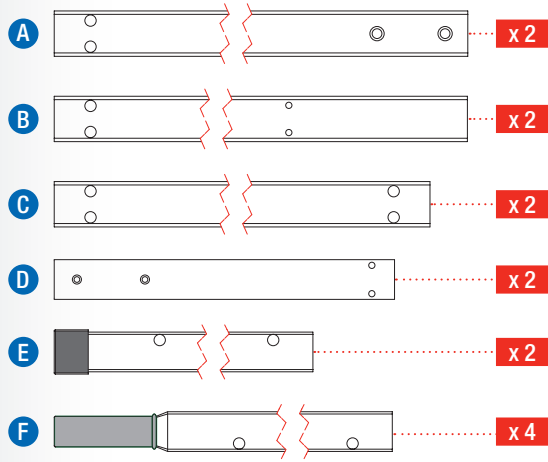

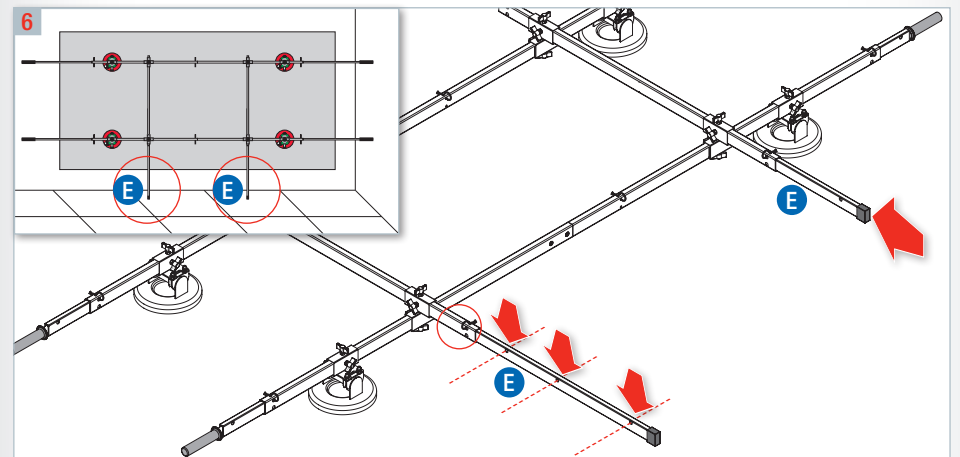
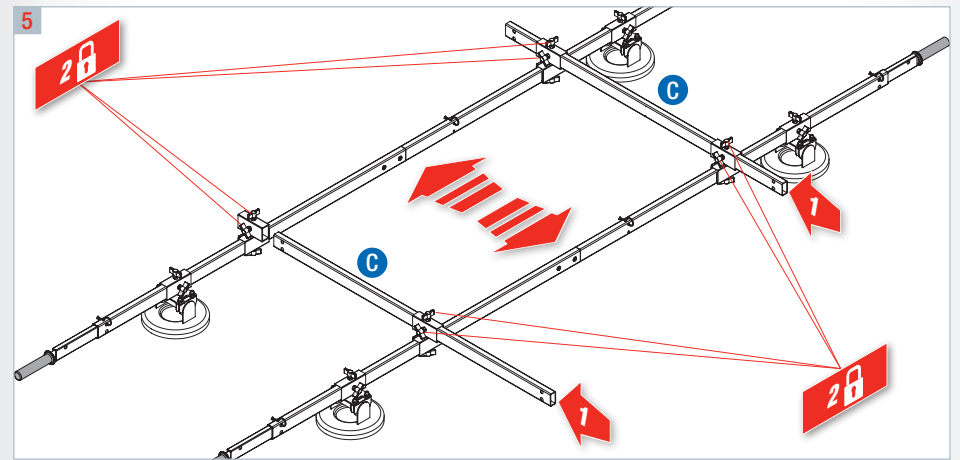
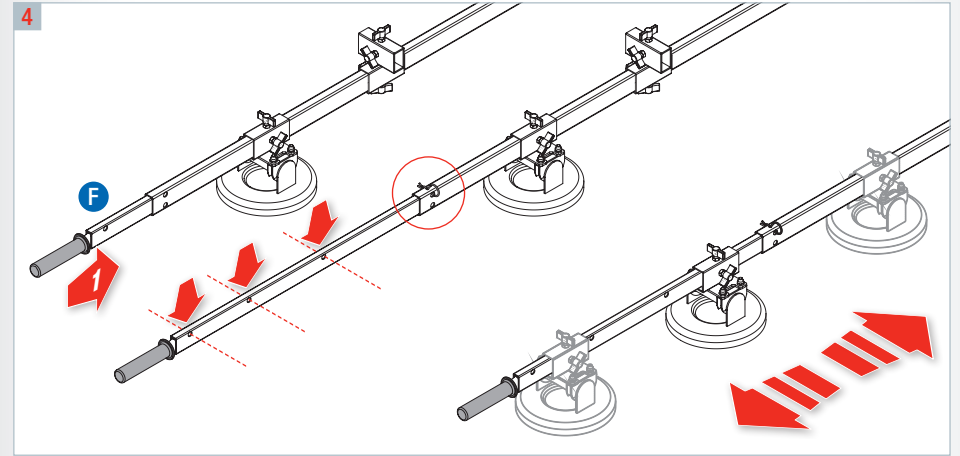
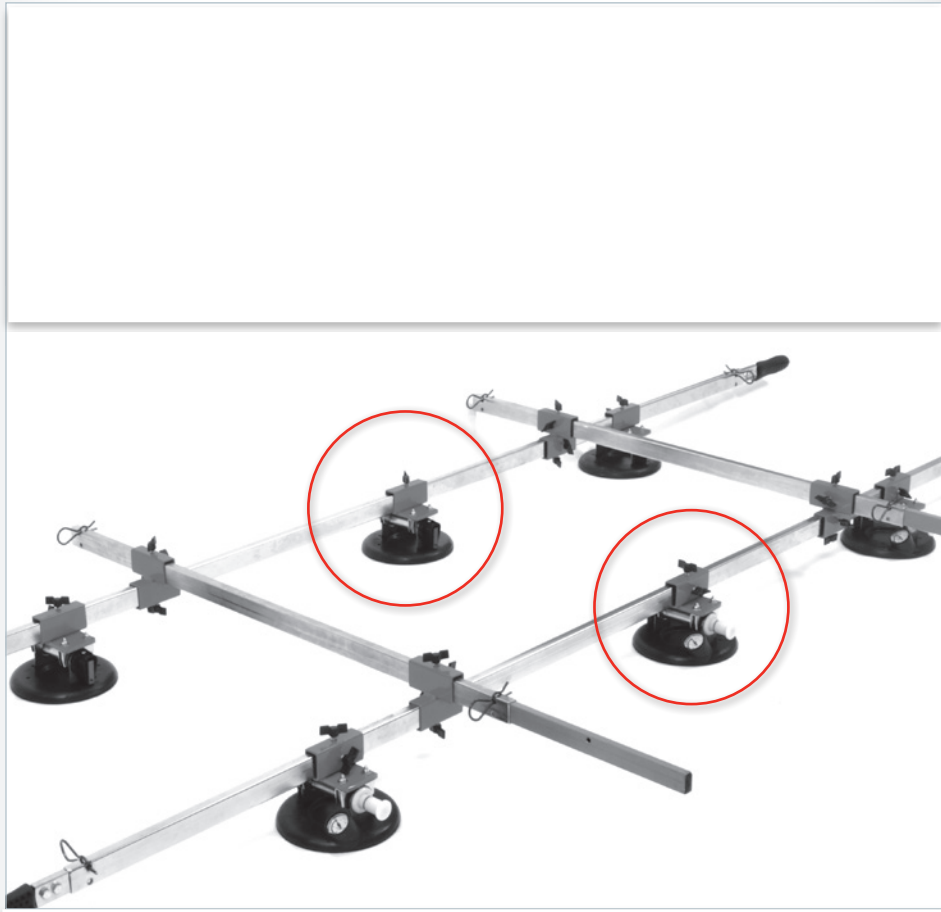

7

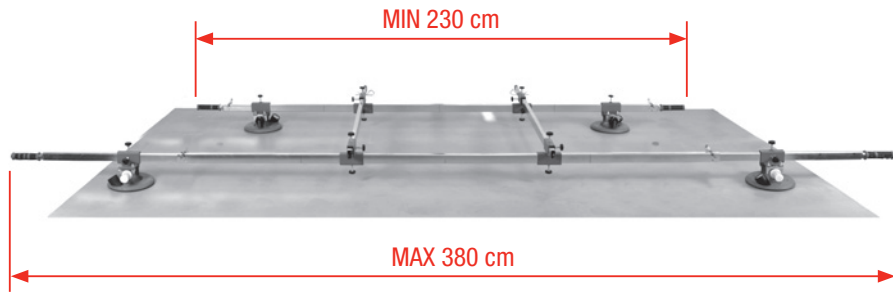

8

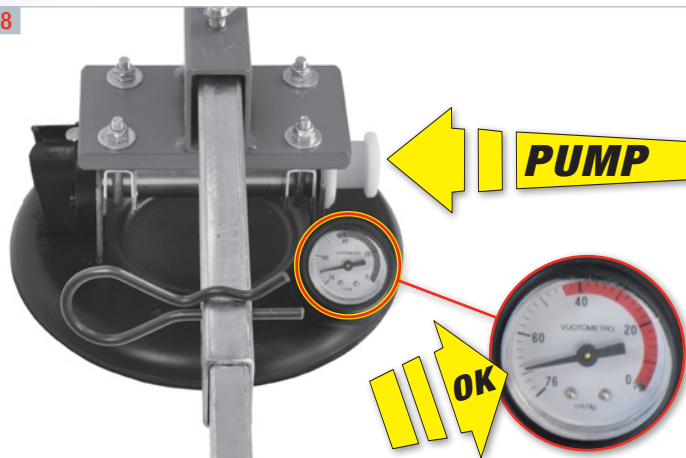

MAX LOAD

80 Kg



ATTENZIONE:
controllare sempre l'integrità delle ventose.

WARNING:
always check the condition of the suction cups.

ATTENTION:
Toujours vérifier l'état des ventouses.

WARNUNG:
Stets den Zustand der Saugnäpfe kontrollieren.

9

